



“ Exceeding Your Expectation ”

“ Leading Into A Greater Future ”

LEADWELL
LEADWELL CNC MACHINES MFG.,CORP.



LEADWELL CNC MACHINES MFG.,CORP.



No.8, Xingke Road, Houli District,
Taichung City 421007, Taiwan R.O.C
TEL: 886-4-25589008
FAX: 886-4-25589027
E-mail: sales@leadwell.com.tw

www.leadwell.com.tw

※ All performance are based on 220V/3PH/60HZ. Specification are subject to change without notice.

T/LTC Series

**Multi-Tasking
Horizontal Turning Center**

**T-8/M/S/SM/XL/XLM
LTC-25i/iL/iXXL/iLV/iM/iLM/iXXLM/iLVM
LTC-30i/iL/iXL/iM/iLM/iXLM**

CNC MULTI-TASKING TURNING CENTER

The slant bed design machine is capable of conducting efficient and precision processing, reducing defect rate, and providing maximum working reliability. Compare to other competitors, this series of models provides less vibration and better construction stability. With higher precision and metal removal rate, this model is applicable for regular components and various metal processing industries.

10.4" LCD & MPG



Parts catcher and parts conveyor

Sheet Metal

Fully enclosed splash guards keep chips and coolant contained for a safe clean working environment.



CE-approved guarding is also available as an optional.

Chip conveyor(optional)

LIVE TOOL TURRET

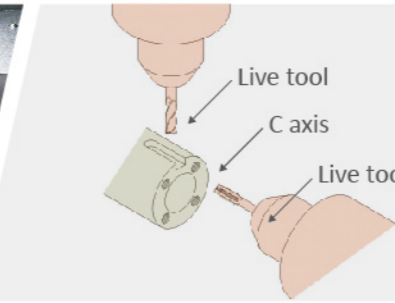

- Each tool can become a rotating tool for both milling and drilling operations.
- Tools can be either radially or axially oriented.

SUB SPINDLE

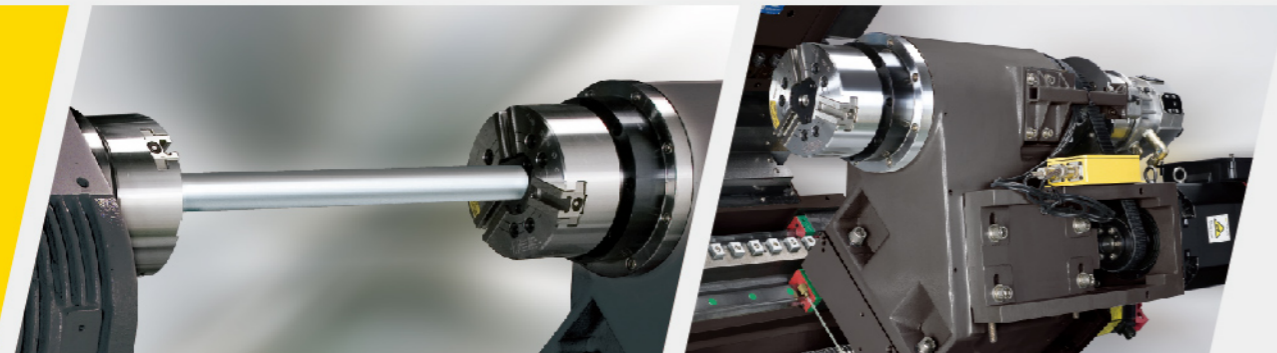

- The sub-spindle replaces the standard tailstock on turning centers.
- A position Czi sensor is attached to the sub-spindle so the sub-spindle can then be synchronized with the main spindle.
- Special software allows the workpiece to be transferred from the main spindle to the sub-spindle at any speed for secondary machining operations.
- Allows machining on both end of parts.



Scraping

The contact surface of the guide, turret, tailstock, main spindle table, ball screw, and base have been scraped accurately to provide the best precision and rigidity.

FEA

Casting are well ribbed based on Finite Element Analysis for the size and location to ensure high torsional stiffness and minimum vibration.

One-Piece Design

One-piece-forged base and saddle with heat treatment and precision grinding can achieve high strength and precision.

STRUCTURE

Sturdy and Durable Machine Body and Guide

The machine frame with 45 degrees slant bed design, manufactured with the best quality Meehanite cast iron body, scientific rib reinforcement, high rigid and vibration tolerance base design, and high precision screw have efficient processing performance.

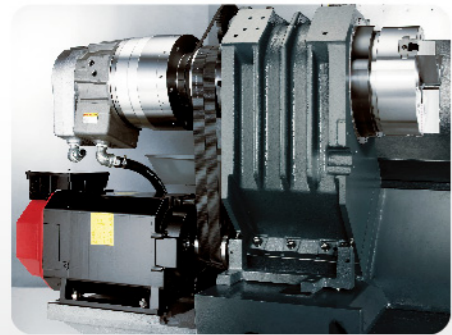

Chuck(optional)

A2-11/12"(2600RPM) bar capacity 103mm
A2-8/12"(2600RPM) bar capacity 85mm



Spindle

High rigidity and long service life.
High precision NN-TYPE spindle bearing from Japan and Europe.

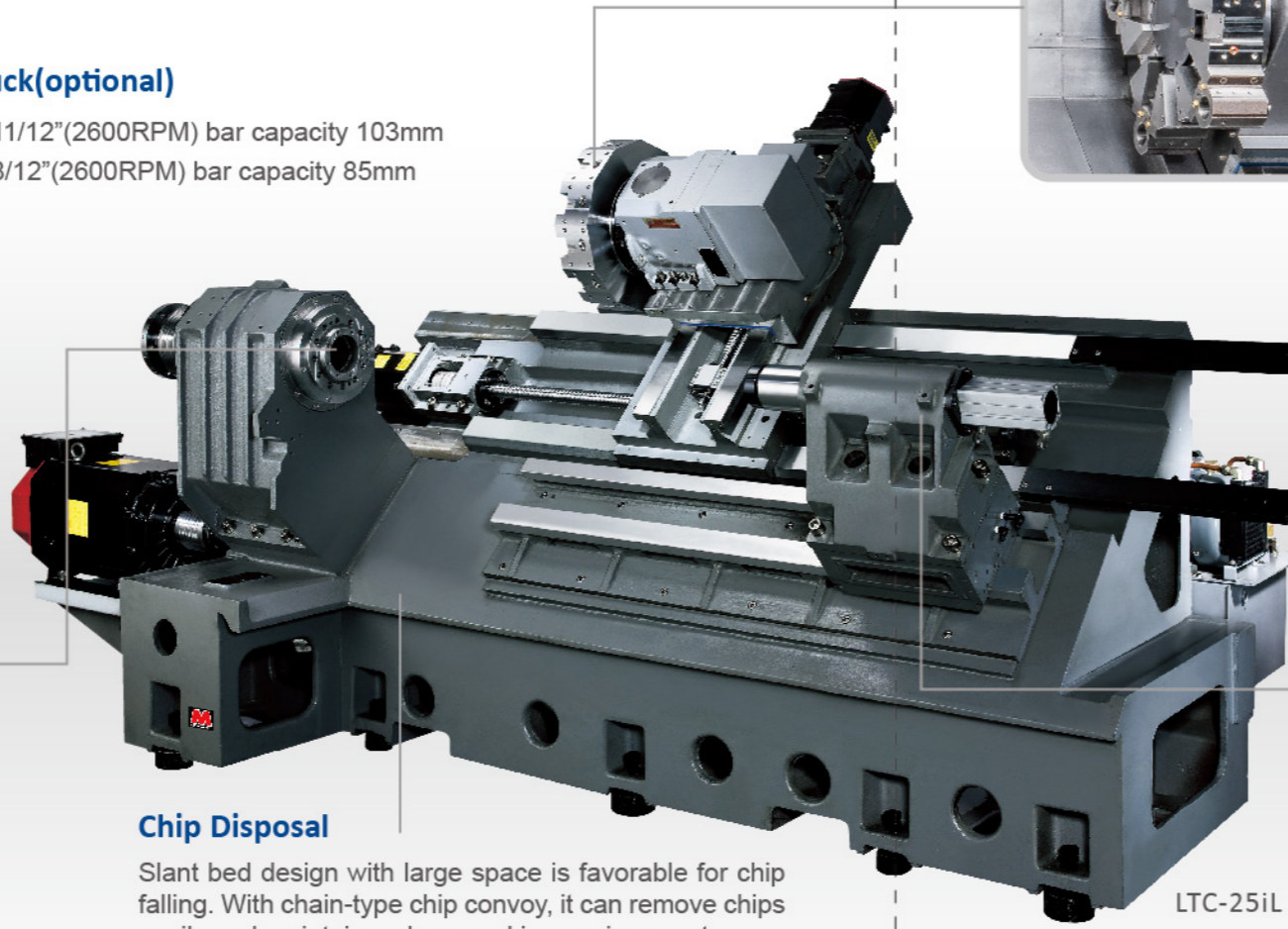

Chip Disposal

Slant bed design with large space is favorable for chip falling. With chain-type chip convoy, it can remove chips easily and maintain a clean working environment.



Standard Turret

12 TOOLS
CLT-100S

Driven by servo, rotating smoothly and easily select the tools to avoid the collision.

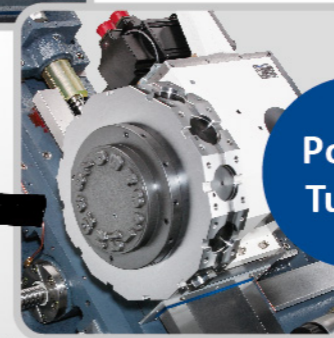

Power Turret

12 TOOLS
VDI-40 Axial
BMT-65 Radial(optional)

With applying for three pieces of curve coupling, indexing belt and offset design to ensure lower noise and backlash while turret rotating.

Tailstock

MT-5(manual)

Sub-Spindle (optional)

To enhance efficiency and reduce accuracy lost due to reversing workpiece manually.

Programmable Tailstock (optional)

Movement By Z-axis sliding plate by M code control.

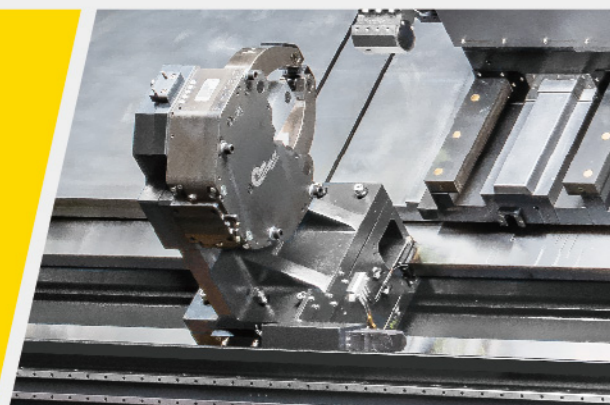

Programmable Hydraulic Steady Rest (optional)

Steady rest to support the workpiece can avoid workpiece bending or tilting during processing. For further processing, dual or multiple hydraulic steady rests can be implemented.

- Max. programmable hydraulic steady rest: SLU3.2(50-200MM) T-8LTC-25i SERIES
- In house manufactured manual steady rest: (80-200MM) T-8/LTC-25i SERIES (140-300MM) T-8/LTC-25i/LTC-30i SERIES



Precision Ball Screw

To apply for high accuracy , low torque fluctuations, and long-term maintenance-free operation by using.



High Speed Linear way

For high-speed cutting, light-duty, higher precision, and lower friction and motor wear. (T series)

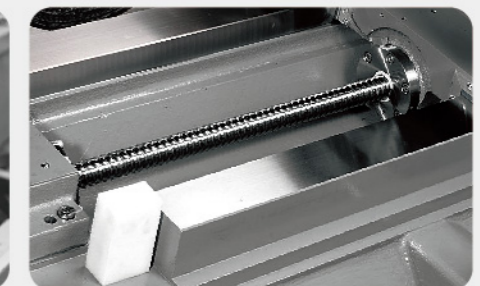

High Rigid Box way

For heavy-duty cutting, stability, fewer vibrations. (LTC series)

LTC-25iL

HIGH PERFORMANCE OPTIONS

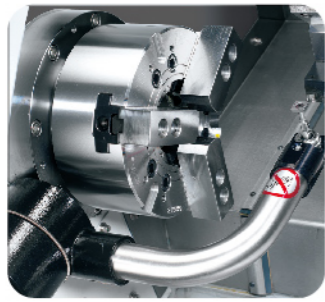

Tool Setter

The tool setter with probe can measure various tool lengths and detect the damaged of tools. Via tool life management, it can be saved all status automatically.

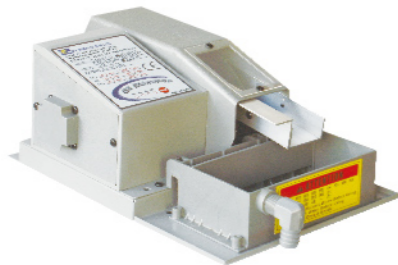

Oil skimmer

Removing foreign matter and water, reducing wastewater emission, and recycling waste oil extend tool service life.



Air Conditioner

Prevent dust, humidity and moisture from entering into the electrical control panel, and improve component life.

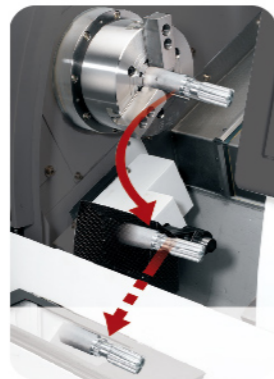

Parts Catcher

The unique parts catcher improves productivity with the bar feeder option, it also can automatically loaded the finished part into bucket, and then to enhance the productivity.



Oil mist collector

Powerful oil mist collecting performance with low cost and high service life can maintain a clean environment.

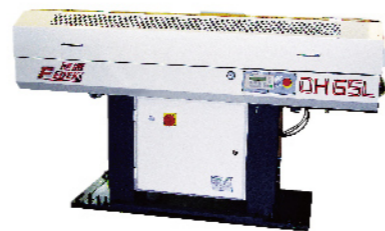

Bar Feeder

The bar feeder is suggested for unattended bar machining and high production requirements. It handles bars ranging from 5 to 65 mm in diameter. Bar loading can be quickly accomplished. Easy parameter setting for various bar sizes.

HIGH QUALITY ASSURANCE

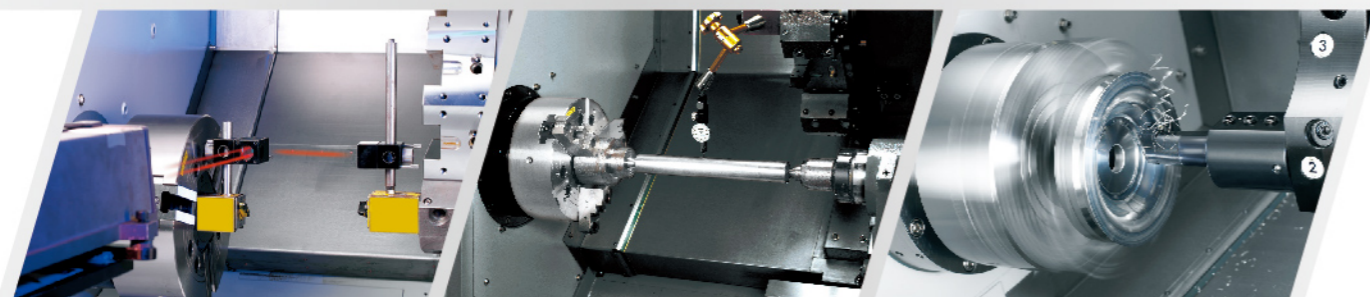

Laser Calibration

Machine Geometric Checking

Cutting and Coolant Testing

CHIP REMOVAL SYSTEM

TYPE	CHAIN	SCRAPER	PRECISION SCRAPER
View			
Process	*chain type:>6mm chips or with round & thin chips *chain type with cylinder brush:>2mm chips or non-round or thin chips	2mm-6mm chips	<6mm chips

CUTTING PERFORMANCE



Material : S45C
Model : LTC-25iLM

	TOOL mm	CUTTING SPEED m/min	SPINDLE SPEED rpm	FEED PER mm/rev	FEED RATE mm/min	CUTTING DEPTH mm
Heavy Cutting	68	225	1053	0.32	336	7
Keyway	5	100	454	0.12	63	3
Fast Drilling	50	160	1000	0.15	150	40
Rigid Tapping	M24XP3	15	200	3	600	35
Power Drilling	20	25	390	0.25	97	40
Power Rigid Tapping	M20XP2.5	10	160	2.5	400	30
Power End Milling Keyway	24	71	930	0.12	220	12

SPINDLE POWER CURVE

— Torque- S1 (Nm) - - - Gbox Torque- S1 (Nm) — Output- S1 (kW) - - - Torque - S3-25% (Nm)
— Torque- S2 30 min (Nm) - - - Gbox Torque- S2 30 min (Nm) — Output- S2 30 min (kW) - - - Output - S3-25% (kW)

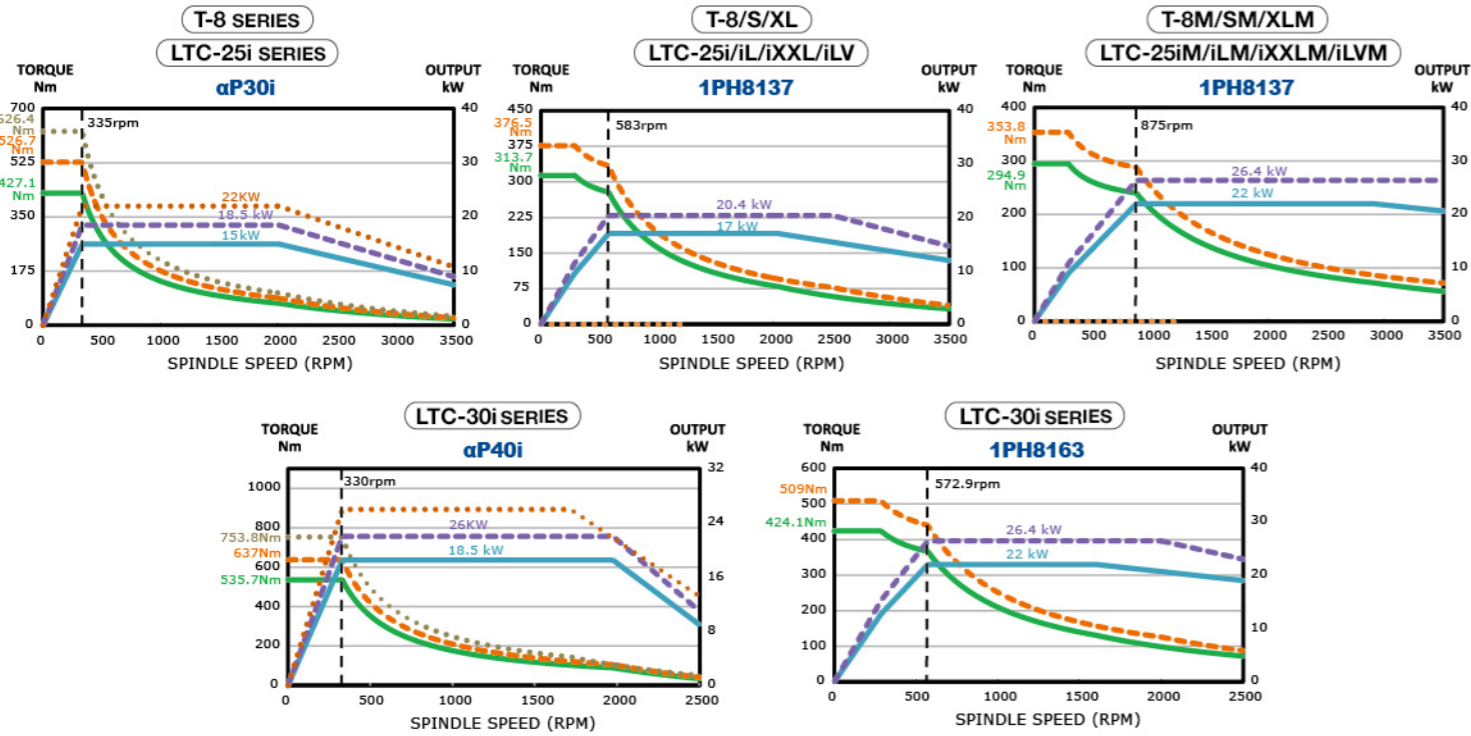

OUTLINE DIMENSION

T-8/M/XL/XLM
LTC-25i/iL/iM/iLM

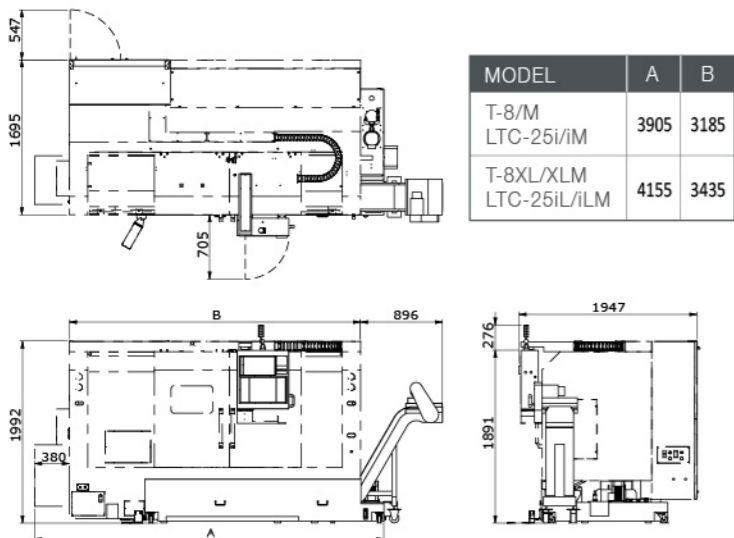

T-8S/SM

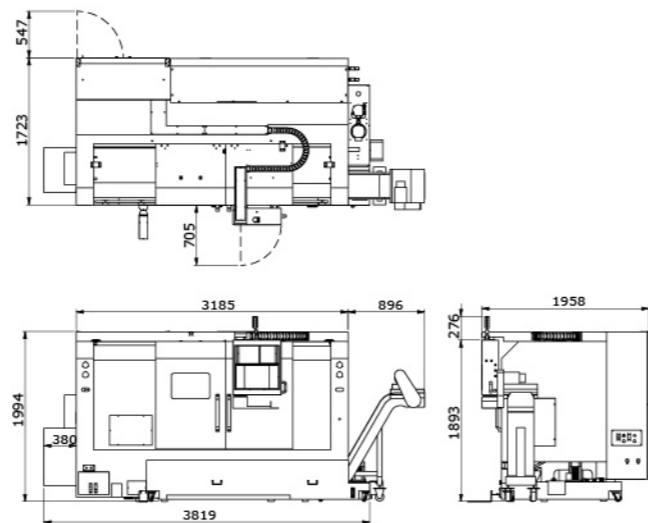

OUTLINE DIMENSION

LTC-25iXXL/iLV
LTC-25iXXLM/iLVM

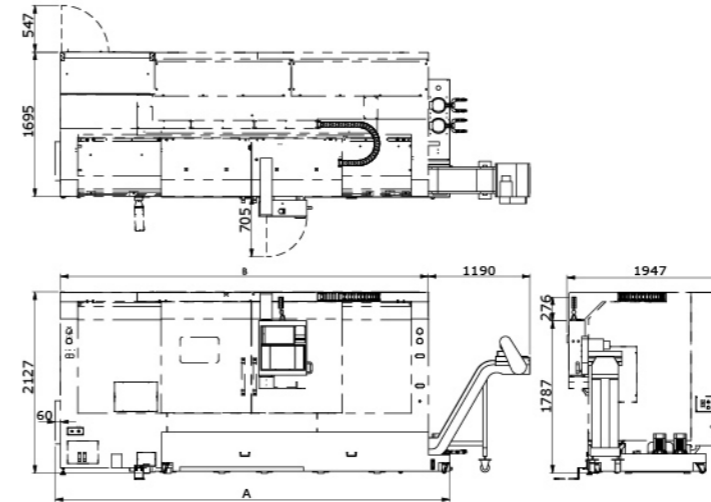

LTC-30i/iL/iXL
LTC-30iM/iLM/iXLM

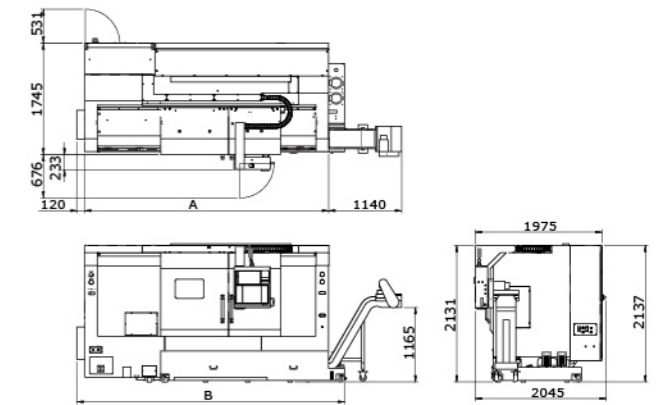

TOOL SYSTEM

T-8/XL
LTC-25i/iL/iXXL/iLV

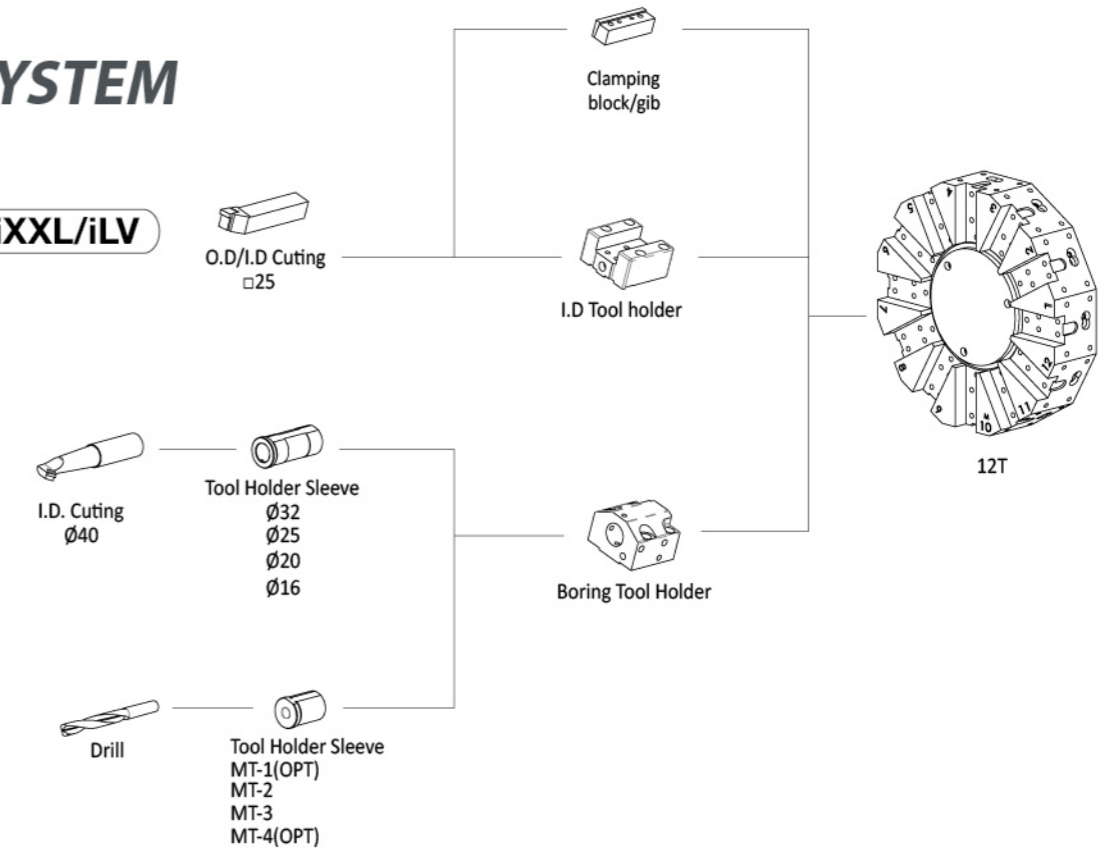

TOOL SYSTEM

T-8S

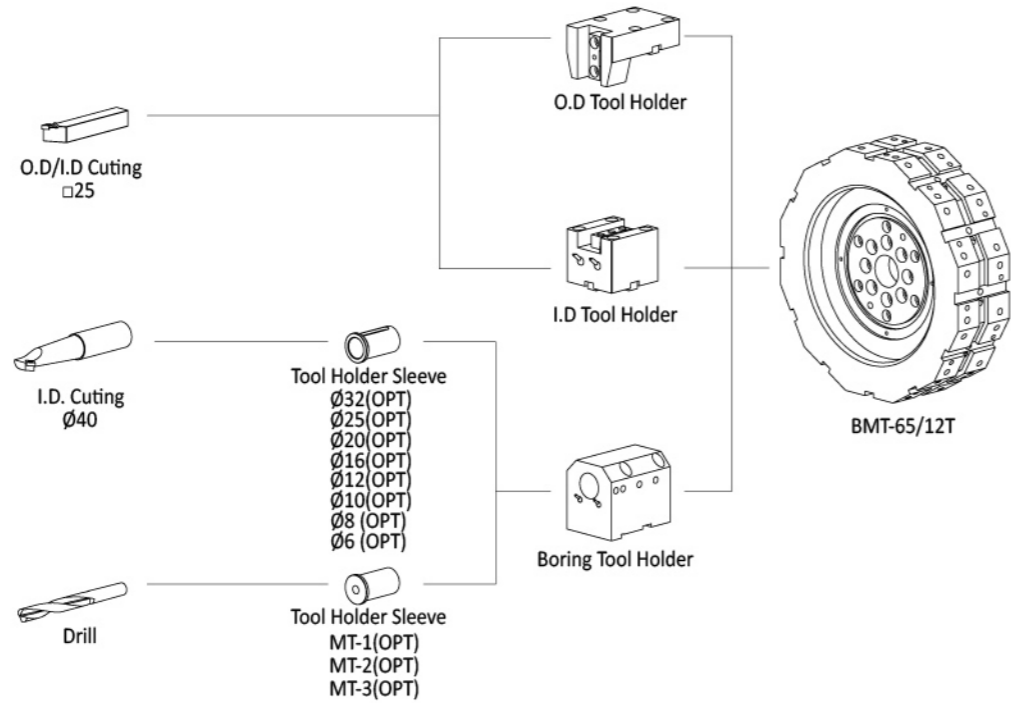

T-8SM

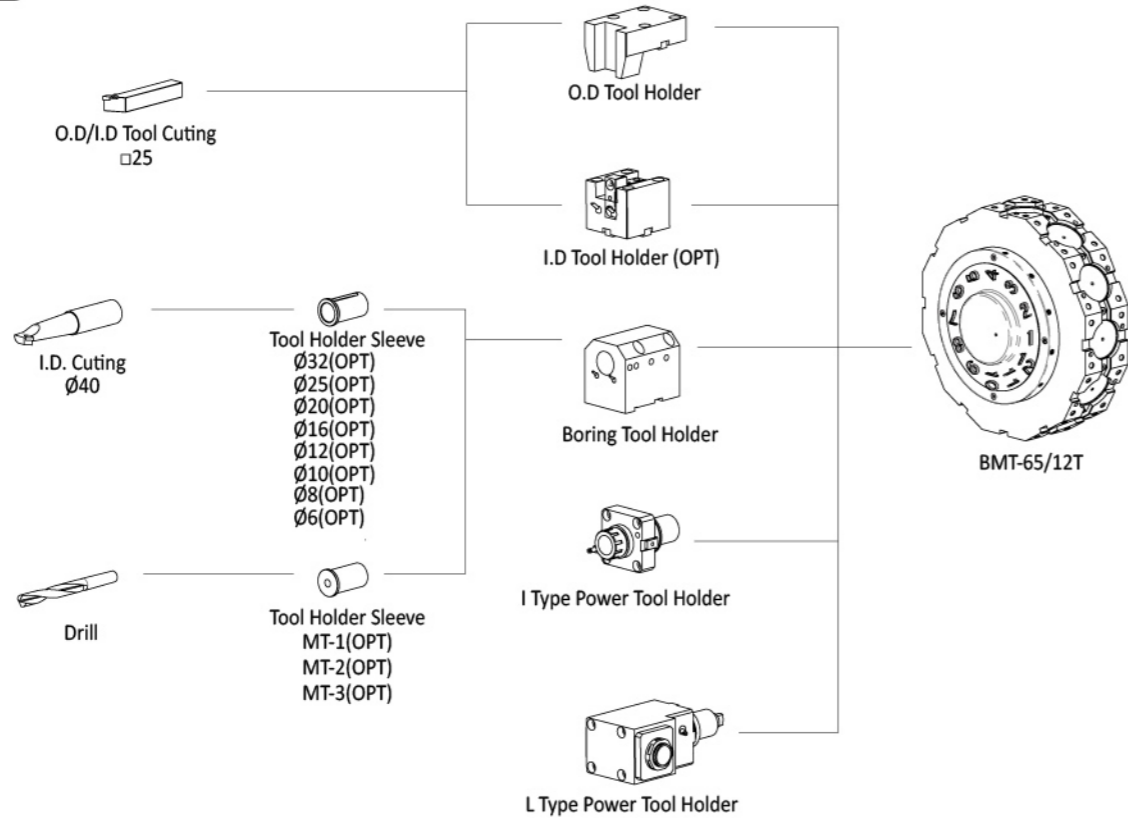

TOOL SYSTEM

T-8M/XLM

LTC-25iM/iLM/iXXLM/iLVM

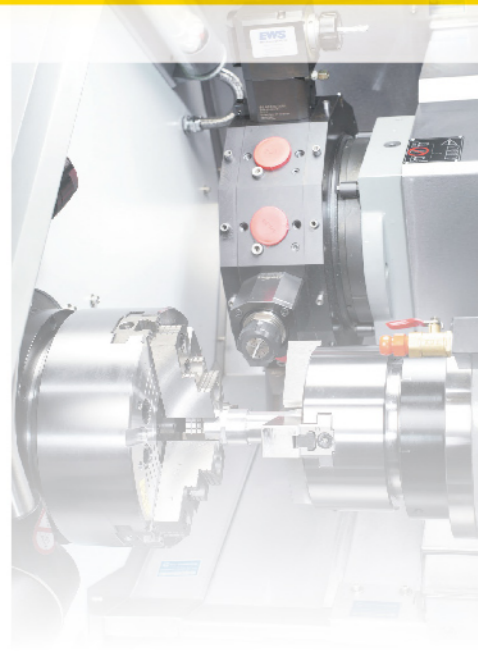
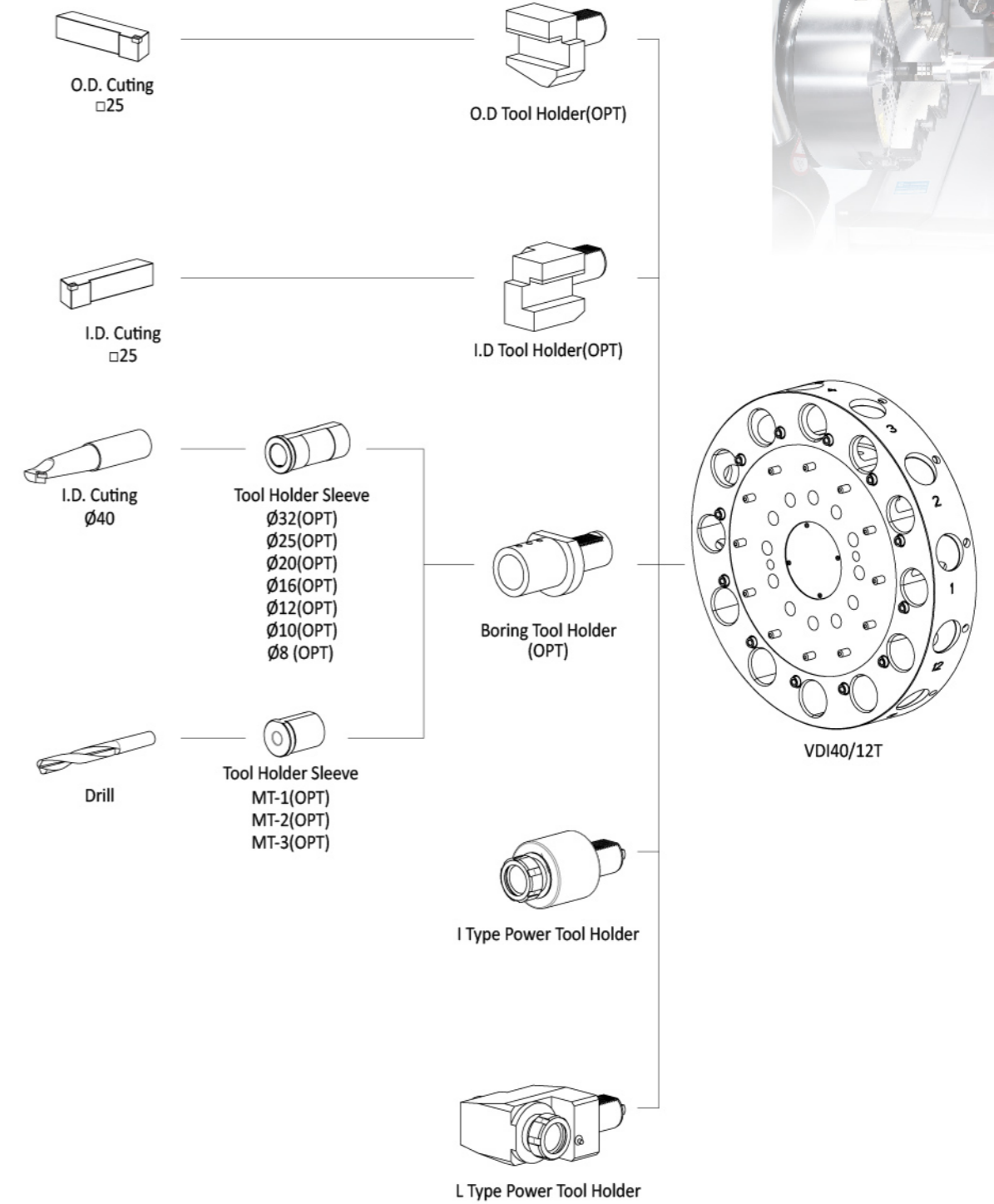

TOOL SYSTEM

LTC-30i/iL/iXL

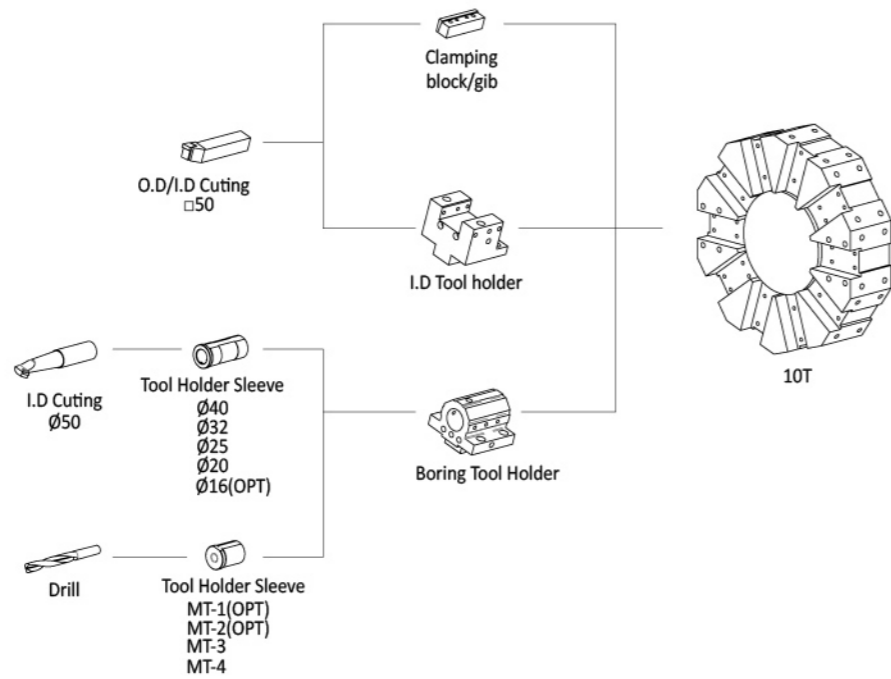

LTC-30iM/iLM/iXLM

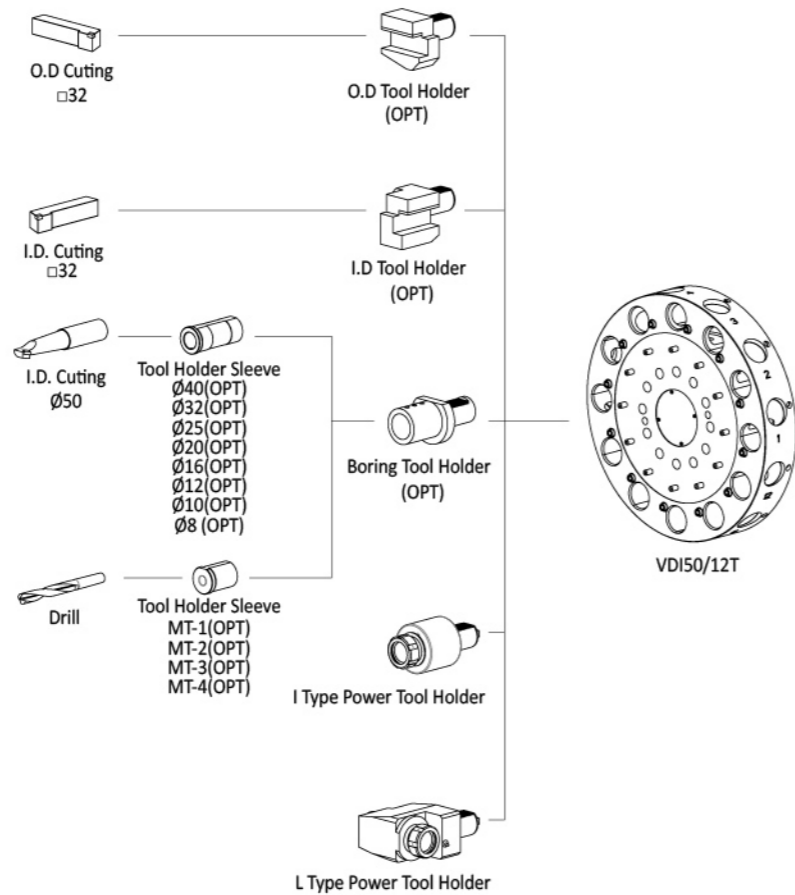

TOOLING INTERFERENCE

T-8/XL

LTC-25i/iL/iXXL/iLV

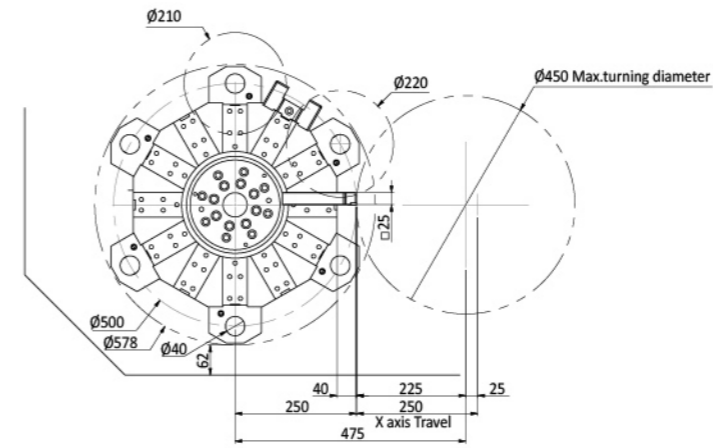

T-8S

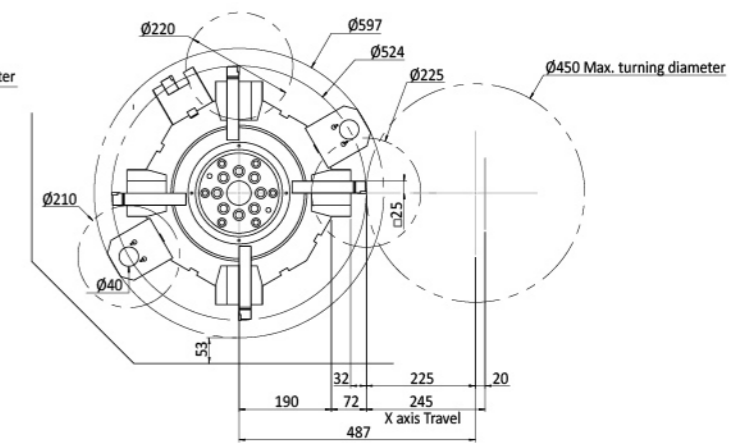

T-8SM

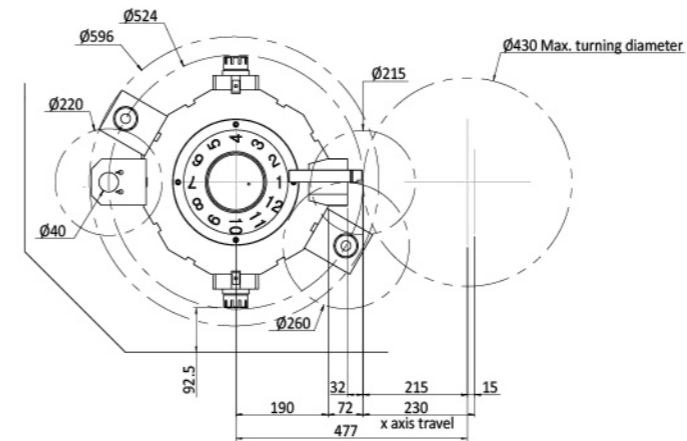

T-8M/XLM

LTC-25iM/iLM/iXXLM/iLVM

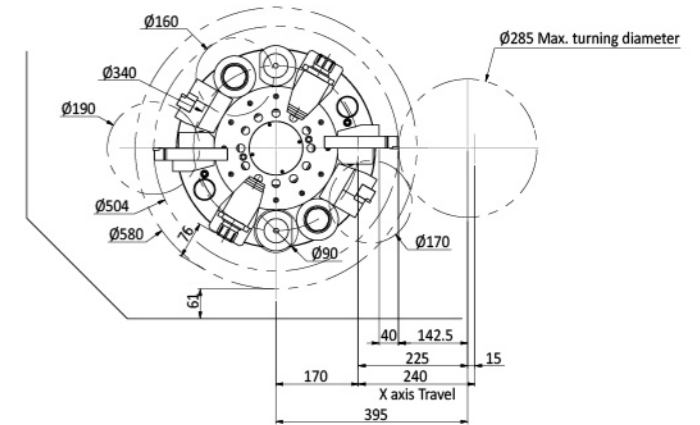

LTC-30i/iL/iXL

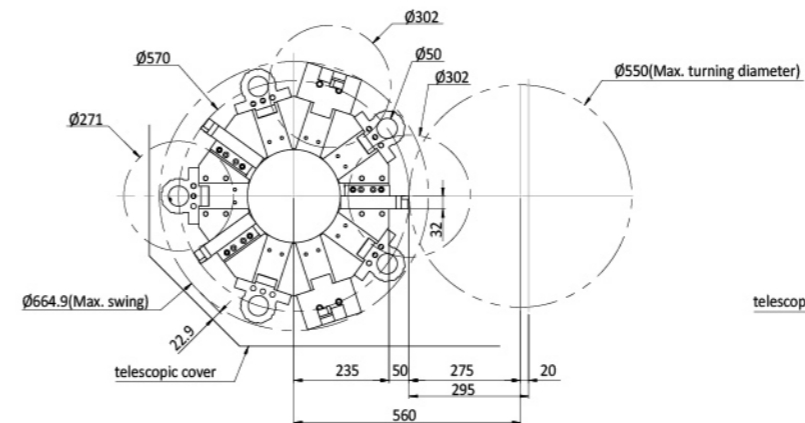

LTC-30iM/iLM/iXLM

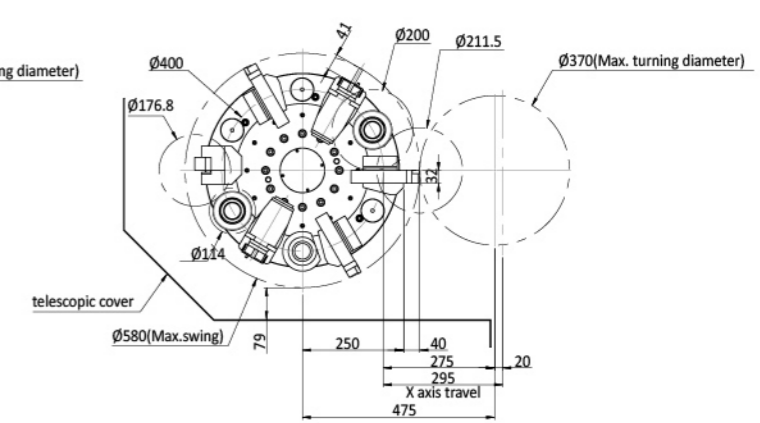

WORKING CAPACITY

T-8/XL

LTC-25i/iL/iXXL/iLV

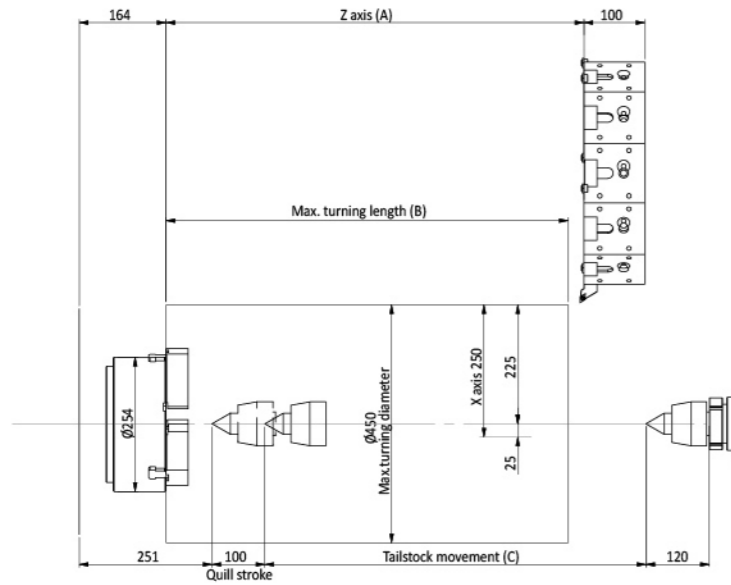

MODEL	A	B	C
T-8/LTC-25i	790	760	720
T-8XL/LTC-25iL	1050	1020	970
LTC-25iXXL	1550	1520	1520
LTC-25iLV	2050	2020	2020

T-8S

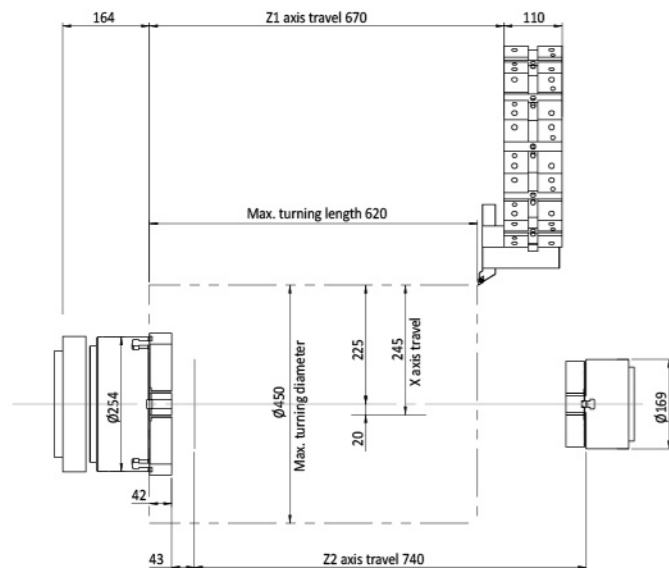

T-8SM

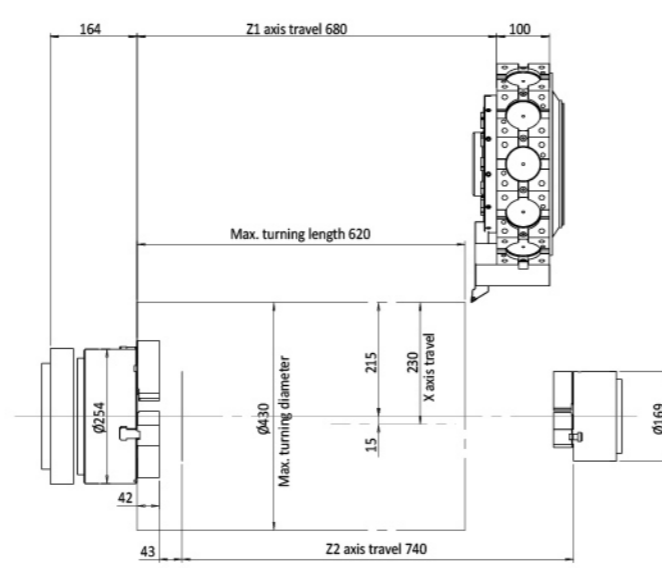

T-8M/XLM

LTC-25iM/iLM/iXXLM/iLVM

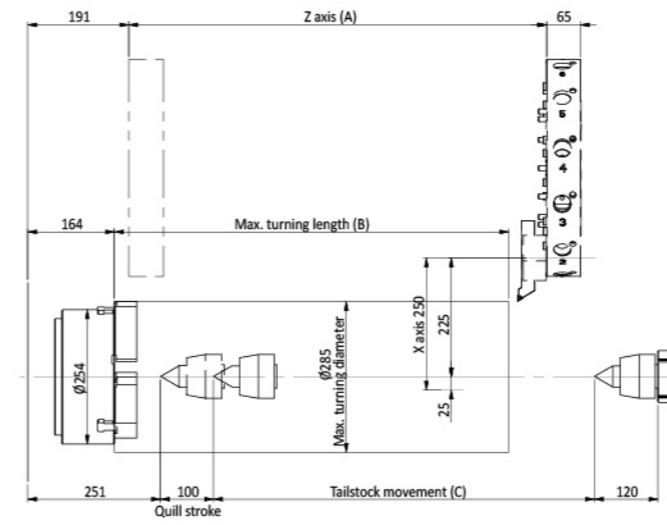

MODEL	A	B	C
T-8M/LTC-25iM	790	745	720
T-8XLM/LTC-25iLM	1050	1005	970
LTC-25iXXLM	1550	1520	1520
LTC-25iLVM	2050	2020	2020

LTC-30i/iL/iXL

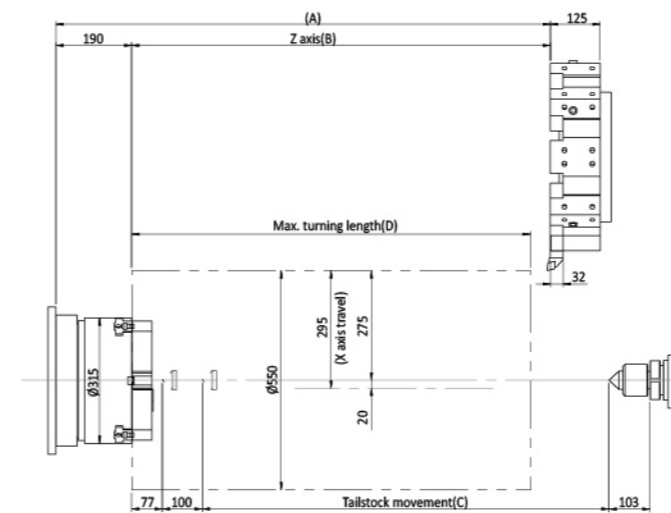

MODEL	A	B	C	D
LTC-30i	1240	1050	1020	1000
LTC-30iL	1740	1550	1520	1500
LTC-30iXL	2240	2050	2020	2000

LTC-30iM/iLM/iXLM

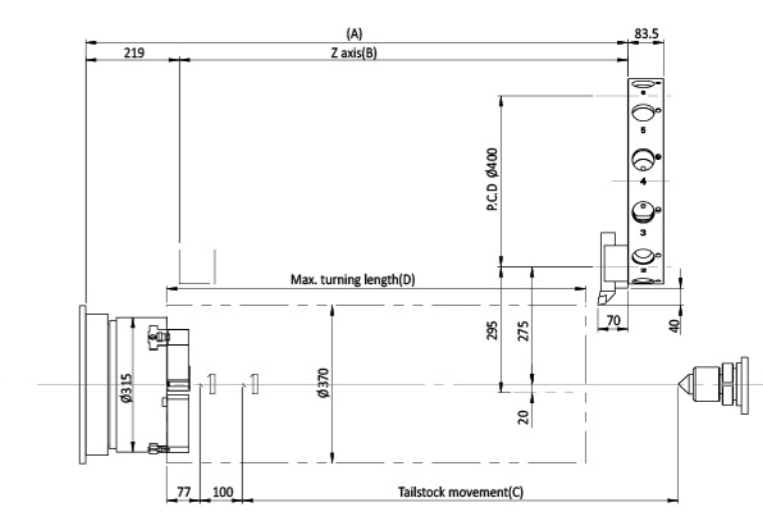

MODEL	A	B	C	D
LTC-30iM	1269	1050	1020	980
LTC-30iLM	1769	1550	1520	1480
LTC-30iXLM	2269	2050	2020	1980

MACHINE SPECIFICATIONS

ITEM	MODEL	T-8	T-8M	T-8S	T-8SM
CAPACITY					
Max. swing	mm(in)	670(26.4)	637(25.1)	600(23.6)	600(23.6)
Max. turning diameter	mm(in)	450(17.7)	STD: 285(11.2) MAX: 325(12.8)	450(17.7)	430(16.9)
Max. turning length	mm(in)	760(29.9)	745(29.3)	620(24.4)	620(24.4)
Bar capacity	mm(in)	77(3)	77(3)	77(3)	77(3)
TRAVEL					
X-axis travel	mm(in)	225+25(8.9+1)	225+15(8.9+0.6)	225+20(8.9+0.8)	215+15(8.5+0.6)
Z-axis travel	mm(in)	790(31.1)	790(31.1)	670(26.4)	680(26.8)
Z2-axis travel	mm(in)	---	---	740(29.1)	740(29.1)
SPINDLE(MAIN)					
Spindle speed	rpm	35-3500	35-3500	35-3500	35-3500
Chuck size	in	10"	10"	10"	10"
Type of spindle nose		A2-8	A2-8	A2-8	A2-8
Spindle motor type	Fanuc	αP30i	αP30i	αP30i	αP30i
Spindle motor power (cont./30min)	kw(hp)	15/18.5(20/24.8)	15/18.5(20/24.8)	15/18.5(20/24.8)	15/18.5(20/24.8)
SPINDLE(SUB)					
Spindle speed	rpm	---	---	45-4500	45-4500
Chuck size	in	---	---	6.5"	6.5"
Type of spindle nose		---	---	A2-5	A2-5
Spindle motor type	Fanuc	---	---	α8i	α8i
Spindle motor power (cont./30min)	kw(hp)	---	---	7.5/11(10/14.7)	7.5/11(10/14.7)
TURRET					
Number of tool stations	pcs	12	12	12	12
Shank height for square tool	mm(in)	25(1)	25(1)	25(1)	25(1)
Shank diameter for boring bar	mm(in)	40(1.5)	40(1.5)	40(1.5)	40(1.5)
Rotary tool spindle speed range: axis units	rpm	---	5000	---	5000
Rotary tool spindle speed range: radial units	rpm	---	5000	---	5000
Rotary tool motor power (cont./30min)	kw(hp)	---	3.5/5.5(5/7.4)	---	3.7/5.5(5/7.4)
FEED RATE					
X/Z/Z2-axis rapid traverse	m/mm(in)	20/24/---(788/945/---)	20/24/---(788/945/---)	20/24/15(788/945/590)	20/24/15(788/945/590)
FEED MOTORS					
X/Z/Z2-axis motor	kw(hp)	3/4/---(4/5.4/---)	3/4/---(4/5.4/---)	3/3/3(4/4/4)	3/3/3(4/4/4)
TAILSTOCK					
Quill diameter	mm(in)	100(3.9)	100(3.9)	---	---
Quill inside taper	M.T	5	5	---	---
MACHINE SIZE					
Floor space(L)	mm(in)	3905(153.7)	3905(153.7)	3932(154.8)	3932(154.8)
Floor space(W)	mm(in)	1930(76)	1930(76)	2125(83.7)	2125(83.7)
Floor space(H)	mm(in)	1980(78)	1980(78)	2120(83.5)	2120(83.5)
Machine weight	kg	6000	6200	6200	6200
Power requirement	KVA	40	45	60	60
controller		0i-TF	0i-TF	0i-TF	0i-TF

*Available controller: SIEMENS/FAGOR/HEIDENHAIN

MACHINE SPECIFICATIONS

ITEM	MODEL	T-8XL	T-8XLM
CAPACITY			
Max. swing	mm(in)	670(26.4)	637(25.1)
Max. turning diameter	mm(in)	450(17.7)	STD: 285(11.2) MAX: 325(12.8)
Max. turning length	mm(in)	1020(40.1)	1005(39.5)
Bar capacity	mm(in)	77(3)	77(3)
TRAVEL			
X-axis travel	mm(in)	225+25(8.9+1)	225+15(8.9+0.6)
Z-axis travel	mm(in)	1050(41.3)	1050(41.3)
SPINDLE(MAIN)			
Spindle speed	rpm	35-3500	35-3500
Chuck size	in	10"	10"
Type of spindle nose		A2-8	A2-8
Spindle motor type	Fanuc	αP30i	αP30i
Spindle motor power (cont./30min)	kw(hp)	15/18.5(20/24.8)	15/18.5(20/24.8)
SPINDLE(SUB)			
Spindle speed	rpm	---	---
Chuck size	in	---	---
Type of spindle nose		---	---
Spindle motor type	Fanuc	---	---
Spindle motor power (cont./30min)	kw(hp)	---	---
TURRET			
Number of tool stations	pcs	12	12
Shank height for square tool	mm(in)	25(1)	25(1)
Shank diameter for boring bar	mm(in)	40(1.5)	40(1.5)
Rotary tool spindle speed range: axis units	rpm	---	5000
Rotary tool spindle speed range: radial units	rpm	---	5000
Rotary tool motor power (cont./30min)	kw(hp)	---	3.5/5.5(5/7.4)
FEED RATE			
X/Z-axis rapid traverse	m/mm(in)	20/24(788/945)	20/24(788/945)
FEED MOTORS			
X/Z-axis motor	kw(hp)	3/4(4/5.4)	3/4(4/5.4)
TAILSTOCK			
Quill diameter	mm(in)	100(3.9)	100(3.9)
Quill inside taper	M.T	5	5
MACHINE SIZE			
Floor space(L)	mm(in)	4155(163.6)	4155(163.6)
Floor space(W)	mm(in)	1930(76)	1930(76)
Floor space(H)	mm(in)	1980(78)	1980(78)
Machine weight	kg	6500	6700
Power requirement	KVA	40	45
controller		0i-TF	0i-TF

*Available controller: SIEMENS/FAGOR/HEIDENHAIN

MACHINE SPECIFICATIONS

ITEM	MODEL	LTC-25i	LTC-25iL	LTC-25iXXL	LTC-25iLV
CAPACITY					
Max. swing	mm(in)	670(26.4)	670(26.4)	670(26.4)	670(26.4)
Max. turning diameter	mm(in)	450(17.7)	450(17.7)	450(17.7)	450(17.7)
Max. turning length	mm(in)	760(29.9)	1020(40.1)	1520(59.8)	2020(79.5)
Bar capacity	mm(in)	77(3)	77(3)	77(3)	77(3)
TRAVEL					
X-axis travel	mm(in)	225+25(8.9+1)	225+25(8.9+1)	225+25(8.9+1)	225+25(8.9+1)
Z-axis travel	mm(in)	790(31.1)	1050(41.3)	1550(61)	2050(80.7)
SPINDLE					
Spindle speed	rpm	35-3500	35-3500	35-3500	35-3500
Chuck size	in	10"	10"	10"	10"
Type of spindle nose		A2-8	A2-8	A2-8	A2-8
Spindle motor type	Fanuc	aP30i	aP30i	aP30i	aP30i
Spindle motor power (cont./30min)	kw(hp)	15/18.5(20/24.8)	15/18.5(20/24.8)	15/18.5(20/24.8)	15/18.5(20/24.8)
TURRET					
Number of tool stations	pcs	12	12	12	12
Shank height for square tool	mm(in)	25(1)	25(1)	25(1)	25(1)
Shank diameter for boring bar	mm(in)	40(1.5)	40(1.5)	40(1.5)	40(1.5)
Rotary tool spindle speed range: axis units	rpm	---	---	---	---
Rotary tool spindle speed range: radial units	rpm	---	---	---	---
Rotary tool motor power (cont./30min)	kw(hp)	---	---	---	---
FEED RATE					
X/Z-axis rapid traverse	m/mm(in)	15/20(590/788)	15/20(590/788)	15/20(590/788)	15/20(590/788)
FEED MOTORS					
X/Z-axis motor	kw(hp)	3/4(4/5.4)	3/4(4/5.4)	3/4(4/5.4)	3/4(4/5.4)
TAILSTOCK					
Quill diameter	mm(in)	100(3.9)	100(3.9)	100(3.9)	100(3.9)
Quill inside taper	M.T	5	5	5	5
MACHINE SIZE					
Floor space(L)	mm(in)	3905(153.7)	4155(163.6)	4625(182)	5355(211)
Floor space(W)	mm(in)	1930(76)	1930(76)	1930(76)	1930(76)
Floor space(H)	mm(in)	1980(78)	1980(78)	2140(84.3)	2140(84.3)
Machine weight	kg	6200	6700	8100	9100
Power requirement	KVA	40	40	40	40
controller		0i-TF	0i-TF	0i-TF	0i-TF

*Available controller: SIEMENS/FAGOR/HEIDENHAIN

MACHINE SPECIFICATIONS

ITEM	MODEL	LTC-25iM	LTC-25iLM	LTC-25iXXLM	LTC-25iLVM
CAPACITY					
Max. swing	mm(in)	637(25.1)	637(25.1)	637(25.1)	637(25.1)
Max. turning diameter	mm(in)	STD: 285(11.2) MAX: 325(12.8)	STD: 285(11.2) MAX: 325(12.8)	STD: 285(11.2) MAX: 325(12.8)	STD: 285(11.2) MAX: 325(12.8)
Max. turning length	mm(in)	745(29.3)	1005(39.5)	1520(59.8)	2020(79.5)
Bar capacity	mm(in)	77(3)	77(3)	77(3)	77(3)
TRAVEL					
X-axis travel	mm(in)	225+15(8.9+0.6)	225+15(8.9+0.6)	225+15(8.9+0.6)	225+15(8.9+0.6)
Z-axis travel	mm(in)	790(31.1)	1050(41.3)	1550(61)	2050(80.7)
SPINDLE					
Spindle speed	rpm	35-3500	35-3500	35-3500	35-3500
Chuck size	in	10"	10"	10"	10"
Type of spindle nose		A2-8	A2-8	A2-8	A2-8
Spindle motor type	Fanuc	aP30i	aP30i	aP30i	aP30i
Spindle motor power (cont./30min)	kw(hp)	15/18.5(20/24.8)	15/18.5(20/24.8)	15/18.5(20/24.8)	15/18.5(20/24.8)
TURRET					
Number of tool stations	pcs	12	12	12	12
Shank height for square tool	mm(in)	25(1)	25(1)	25(1)	25(1)
Shank diameter for boring bar	mm(in)	40(1.5)	40(1.5)	40(1.5)	40(1.5)
Rotary tool spindle speed range: axis units	rpm	5000	5000	5000	5000
Rotary tool spindle speed range: radial units	rpm	5000	5000	5000	5000
Rotary tool motor power (cont./30min)	kw(hp)	3.5/5.5(5/7.4)	3.5/5.5(5/7.4)	3.5/5.5(5/7.4)	3.5/5.5(5/7.4)
FEED RATE					
X/Z-axis rapid traverse	m/mm(in)	15/20(590/788)	15/20(590/788)	15/20(590/788)	15/20(590/788)
FEED MOTORS					
X/Z-axis motor	kw(hp)	3/4(4/5.4)	3/4(4/5.4)	3/4(4/5.4)	3/4(4/5.4)
TAILSTOCK					
Quill diameter	mm(in)	100(3.9)	100(3.9)	100(3.9)	100(3.9)
Quill inside taper	M.T	5	5	5	5
MACHINE SIZE					
Floor space(L)	mm(in)	3905(153.7)	4155(163.6)	4625(182)	5355(211)
Floor space(W)	mm(in)	1930(76)	1930(76)	1930(76)	1930(76)
Floor space(H)	mm(in)	1980(78)	1980(78)	2140(84.3)	2140(84.3)
Machine weight	kg	6200	6700	8100	9100
Power requirement	KVA	45	45	45	45
controller		0i-TF	0i-TF	0i-TF	0i-TF

*Available controller: SIEMENS/FAGOR/HEIDENHAIN

MACHINE SPECIFICATIONS

ITEM	MODEL	LTC-30i/iXL/iXXL	LTC-30iM/iLM/iXLM
CAPACITY			
Max. swing	mm(in)	750(29.5)	750(29.5)
Max. turning diameter	mm(in)	550(21.6)	370(14.5)
Max. turning length	mm(in)	1000/1500/2000(39.4/59/78.7)	980/1480/1980(38.6/58.3/78)
Bar capacity	mm(in)	103(4)	103(4)
TRAVEL			
X-axis travel	mm(in)	275+20(10.8+0.8)	275+15(10.8+0.6)
Z-axis travel	mm(in)	1050/1550/2050(41.3/61/80.7)	1050/1550/2050(41.3/61/80.7)
SPINDLE			
Spindle speed	rpm	35-2500	35-2500
Chuck size	in	12"	12"
Type of spindle nose		A2-11	A2-11
Spindle motor type	Fanuc	aP40i	aP40i
Spindle motor power (cont./30min)	kw(hp)	18.5/22(24.8/29.5)	18.5/22(24.8/29.5)
TURRET			
Number of tool stations	pcs	10	12
Shank height for square tool	mm(in)	32(1.2)	32(1.2)
Shank diameter for boring bar	mm(in)	50(2)	50(2)
Rotary tool spindle speed range: axis units	rpm	---	5000
Rotary tool spindle speed range: radial units	rpm	---	5000
Rotary tool motor power (cont./30min)	kw(hp)	---	5.5/7.5(7.4/10)
FEED RATE			
X/Z-axis rapid traverse	m/mm(in)	15/20(590/788)	15/20(590/788)
FEED MOTORS			
X/Z-axis motor	kw(hp)	3/4(4/5.4)	3/4(4/5.4)
TAILSTOCK			
Quill diameter	mm(in)	100(3.9)	100(3.9)
Quill inside taper	M.T	5	5
MACHINE SIZE			
Floor space(L)	mm(in)	4190/4690/5190(164.9/184.6/204.3)	4190/4690/5190(164.9/184.6/204.3)
Floor space(W)	mm(in)	1980(78)	1980(78)
Floor space(H)	mm(in)	2165(85.2)	2165(85.2)
Machine weight	kg	6700/7700/8700	6700/7700/8700
Power requirement	KVA	45	55
controller		Oi-TF	Oi-TF

*Available controller: SIEMENS/FAGOR/HEIDENHAIN

MACHINE ACCESSORIES

ITEM	MODEL	T-8	T-8M	T-8S	T-8SM	T-8XL	T-8XLM
Metric disc		●	×	×	×	●	×
Manual tailstock		●	●	×	×	●	●
Buzzer		●	●	●	●	●	●
Three layers warning light		●	●	●	●	●	●
Heat exchanger		●	●	●	●	●	●
Full enclosed splash guard		●	●	●	●	●	●
3 jaw open center chuck		●	●	●	●	●	●
Foot switch		●	●	●	●	●	●
Wide angle V-belt		●	●	●	●	●	●
Inch disc		■	×	×	×	■	×
VDI disc		■	●	×	×	■	●
Tool setter		■	■	■	■	■	■
Programmable tailstock		■	■	×	×	■	■
Manual steady rest		■	■	×	×	■	■
Air conditioner		■	■	■	■	■	■
Bar feeder		■	■	■	■	■	■
Spindle air outer blow		■	■	■	■	■	■
High pressure pump 4bar		■	■	■	■	■	■
Chip conveyor and bucket		■	■	■	■	■	■
Two speed gearbox		■	■	■	■	■	■
Collet chuck		■	■	■	■	■	■
Oil mist collector		■	■	■	■	■	■
Oil skimmer		■	■	■	■	■	■
H.T.D belt		■	■	■	■	■	■
Auto steady rest with hydraulic		■	■	×	×	■	■
Automatic workpiece measurement		■	■	■	■	■	■
Auto door		■	■	■	■	■	■
Robot		■	■	■	■	■	■
Spindle air inner blow		■	■	■	■	■	■
3 jaw close center chuck		■	■	■	■	■	■
BMT disc		×	■	●	●	×	■

● : STD / ■ : O.P.T(DESIGNED) / × : N/A(NOT AVAILABLE)

MACHINE ACCESSORIES

ITEM \ MODEL	LTC-25i/iL	LTC-25iXXL/iLV	LTC-25iM/iLM	LTC-25iXXLM/iLVM
Metric disc	●	●	X	X
Manual tailstock	●	X	●	X
Buzzer	●	●	●	●
Three layers warning light	●	●	●	●
Heat exchanger	●	●	●	●
Full enclosed splash guard	●	●	●	●
3 jaw open center chuck	●	●	●	●
Foot switch	●	●	●	●
Wide angle V-belt	●	●	●	●
Inch disc	■	■	X	X
VDI disc	■	■	●	●
Tool setter	■	■	■	■
Programmable tailstock	■	■	■	●
Manual steady rest	■	■	■	■
Air conditioner	■	■	■	■
Bar feeder	■	■	■	■
Spindle air outer blow	■	■	■	■
High pressure pump 4bar	■	■	■	■
Chip conveyor and bucket	■	■	■	■
Two speed gearbox	■	■	■	■
Collet chuck	■	■	■	■
Oil mist collector	■	■	■	■
Oil skimmer	■	■	■	■
H.T.D belt	■	■	■	■
Auto steady rest with hydraulic	■	■	■	■
Automatic workpiece measurement	■	■	■	■
Auto door	■	■	■	■
Robot	■	■	■	■
Spindle air inner blow	■	■	■	■
3 jaw close center chuck	■	■	■	■
BMT disc	X	X	■	■

● : STD / ■ : O.P.T(DESIGNED) / X : N/A(NOT AVAILABLE)

MACHINE ACCESSORIES

ITEM \ MODEL	LTC-30i/iL/iXL	LTC-30iM/iLM/iXLM
Metric disc	●	X
Manual tailstock	X	X
Buzzer	●	●
Three layers warning light	●	●
Heat exchanger	●	●
Full enclosed splash guard	●	●
3 jaw open center chuck	●	●
Foot switch	●	●
Wide angle V-belt	X	X
Inch disc	■	X
VDI disc	■	●
Tool setter	■	■
Programmable tailstock	■	●
Manual steady rest	■	■
Air conditioner	■	■
Bar feeder	■	■
Spindle air outer blow	■	■
High pressure pump 4bar	■	■
Chip conveyor and bucket	■	■
Two speed gearbox	■	■
Collet chuck	■	■
Oil mist collector	■	■
Oil skimmer	■	■
H.T.D belt	■	■
Auto steady rest with hydraulic	■	■
Automatic workpiece measurement	■	■
Auto door	■	■
Robot	■	■
Spindle air inner blow	■	■
3 jaw close center chuck	■	■
BMT disc	X	■

● : STD / ■ : O.P.T(DESIGNED) / X : N/A(NOT AVAILABLE)